

EFFICIENT DESIGN OF SOLAR TRACKING SYSTEM FOR EXTRACTING SOLAR ENERGY

SHARAD KUMAR, SHASHANK MISHRA, SHASHANK GUPTA

Electrical Engineering Department, ABES Engineering College, Ghaziabad, U.P

ABSTRACT

The increasing demand for energy, the continuous reduction in existing sources of fossil fuels and the growing concern regarding environmental pollution, have pushed mankind to explore new technologies for the production of electrical energy using clean, renewable sources, such as solar energy, wind energy, etc. Among the non-conventional, renewable energy sources, solar energy affords a great potential for conversion into electric power, able to ensure an important part of the electrical energy needs of the planet. Solar energy is free, practically inexhaustible, and involves no polluting residues or greenhouse gas emissions.

This paper deals with the design and execution of a solar tracker system dedicated to the PV conversion panels. The proposed single axis solar tracker device and dual axis solar tracker device ensures the optimization of the conversion of solar energy into electricity by properly orienting the PV panel in accordance with the real position of the sun. The operation of the experimental model of the device is based on a DC motor intelligently controlled by a dedicated drive unit that moves a mini PV panel according to the signals received from two simple but efficient light sensors.

Index Terms - solar tracker system, greenhouse gas emissions, microcontroller, single axis solar tracker device, dual axis solar tracker device.

1. INTRODUCTION

The conversion of solar light into electrical energy represents one of the most promising and challenging energetic technologies, in continuous development, being clean, silent and reliable, with very low maintenance costs and minimal ecological impact. A photovoltaic panel is a device used to capture the sun's radiation. These panels consist of an array of solar cells. The solar cells are made up of silicon (sand). They are then connected to complete a photovoltaic (solar) panel. When the sun rays are incident on the solar cells, due to the photovoltaic effect, light energy from the sun is used to convert it to electrical energy. We know that most of the energy gets absorbed, when the panel's surface is perpendicular to the sun. Stationary mounted PV (photo voltaic) panels are only perpendicular to sun once a day but the challenge for is to get maximum energy from the source, so for it we use trackers on which the whole system is mounted. In tracking system, solar panels move according to the movement of sun throughout the day. There are three methods of tracking: active, passive, chronological and manual tracking

systems. In active tracking system, the position of the sun is determined by the sensors. These sensors will trigger the motor to move the mounting system so that the panels will always face the sun rays perpendicular to it throughout the day. But in this system it is very difficult for sensors to determine the position of sun in cloudy days. So it is not a very accurate. In its Passive tracking systems, which determines the position of the sun by moving the panels in response to an imbalance pressure between the two points at both ends of the trackers. The imbalance pressure caused by solar heat creates a gas pressure on a low boiling point compressed gas fluid that is driven to one side or the other accordingly, which then moves the system. This method is also not accurate as the shade /reflectors that are used to reflect early morning sunlight to “wake up” the panel and tilt it towards the sun can take nearly an hour to do so. A chronological tracker is a timer-based tracking system whereby the structure is moved at a fixed rate throughout the day. The theory behind this is that the sun moves across the sky at a fixed rate. Thus the motor or actuator is programmed to continuously rotate at a ‘slow average rate of one revolution per day (15 degrees per hour)’. This method of sun-tracking is very accurate. However, the continuous rotation of the motor or actuator means more power consumption and tracking the sun. In manual tracking system, drives are replaced by operators who adjust the trackers. This has the benefits of robustness, having staff available for maintenance and creating employment for the population in the vicinity of the site.

2. COMPONENTS OF SOLAR TRACKER

2.1-Solar panel- A solar panel is a collection of solar cells spread over a large area and can work together to provide enough power to be useful. The more light that hits a cell, the more electricity it produces.

2.2-Light Dependent Resistors_- The solar tracker system will obtain its data from two CDS (Cadmium Sulfide) photocells, which are type of LDR. The material used in CDS photocell is of high resistance semiconductor. Therefore, once light falls on its surface, photons absorbed by the semiconductor will give bound electrons enough energy to jump in to the conduction band. As the result free electrons conduct electricity and thus lower the resistance. In case of high intensity, photocell will produce lowest resistance, the opposite will occur in case of complete darkness.

2.3-Stepper Motor- Stepper motors are commonly used in precision positioning control system. It is brushless, load independent, has open loop positioning capability, good holding torque and excellent response characteristics. It divides a full rotation into a number of equal steps.

2.4-Microcontroller- It is the heart of this overall system. It requires 5 volt voltage supply. Voltage regulator is used to fix 5 volt supply to microcontroller. It has some specific parts given below:

- *-Analog to digital converter
- *- Analog comparator
- *- Timer
- *- Algorithm

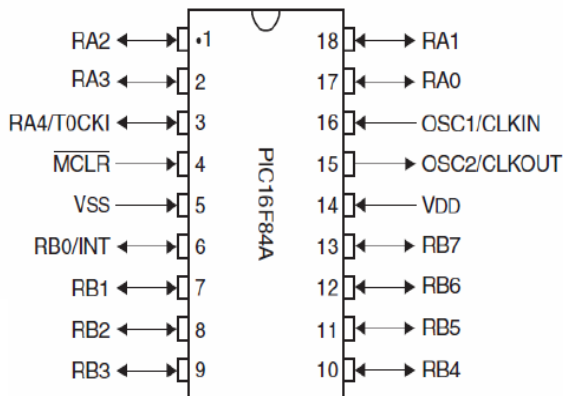

MICROCONTROLLER

3. CONSTRUCTION AND WORKING

3.1 Construction: Two CDS cells are connected to port RB2 and RB3 of the PIC. In figure 1, the two photocells are positioned on a small straight piece of wood or plastic. Another piece is mounted perpendicular to the straight piece, thereby dividing both the sensors. If both the photocells are equally illuminated by the sun, their resistance level will be same. As long as the resistance is same, an error margin of ± 10 points, the PIC will analyze this data and thus will not generate any signal to actuate the motor. Whereas in the case of figure 2, if one of the sensor comes under a shadow, then the PIC will detect this change and thus it will actuate the motor to move the sensor module to a position where equal light is being illuminated on both of them. The PIC is programmed so that it can obtain its resistance data from the two LDRs and to move motor either clock wise or anti clock wise depending on which LDR is under shadow. The concept of the software design is dependent on the LDR that is under shadow.



Sensor Module (FIGURE-1)

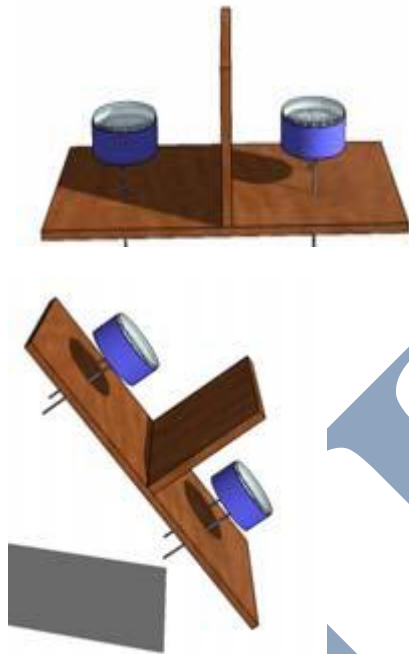

Operation sensor module once an LDR comes under shadow

3.2 Operation of the solar tracker: Solar tracker works by using a PIC16F84A microcontroller which compares light intensity illuminated onto the LDRs. The logic that works on the Microcontroller to detect the signal is based on a resistance capacitor timing circuit, (RC constant), this is necessary in order to set the pre-scalars on the program that will be stored inside the microcontroller. Once the signal is fed into the input for RB2 and RB3, the program compares the two inputs and then the differences are detected and send an output signal from port RB0 and RB1 to let the motor move clockwise and counter clock wise respectively. The signal that is sent from output port RB0 and RB1 is logic level of 1 and 0, logic 1 is high level and 0 is for low level, when logic high is sent to the base of the transistor, it energizes and makes a closed circuit, thus a current flows through the motor, only two transistors can be switched on and off at a time The materials used in the construction of this prototype include Polyvinyl

Chloride (PVC), one and a half inch pipes, wooden base of Medium-density fiberboard (MDF), stool which can rotate 360 degrees, automotive motor and bicycle gear mechanism. The description on how each section of the prototype is built is as follows:

Five pieces of PVC pipe with equal length are connected back to back onto a T-junction and each junction is connected to L-shaped PVC making a stable base onto which the motor can be mounted. The length of each PVC pipe is approximately 0.5 meter. A wooden base is placed on top of the square shaped design, the motor is then mounted below the wooden board, this way the motor is upside down thus its gear is facing downward as well. The hydraulics portion of the revolving office chair is used which can rotate 360 degrees. A gear is then welded onto the hydraulics part using an electric welding machine. The chair is mounted onto the wooden base; this base has dimensions of one meter by 0.8 meter in length and width respectively. Once the hydraulic portion is mounted, the PVC base is placed in a position so that the small gear on the motor is in perfect alignment with the big gear which is mounted on the hydraulics. Once the two gears are aligned they are connected by a steel chain. The gear that is mounted on the motor has 14 teeth and that which is mounted on hydraulics portion has 30 teeth. These specific teeth are chosen because this combination produces more torque on less speed thus less current has to be applied to the motor, this concept is used for both the axes of movement. The horizontal axis is constructed by using two PVC pipes of size three inches in diameter, which are cut to length of 0.3 meters in height, the (MDF) wood is then later cut, 0.4 meter by 0.3 meter in length and width respectively. The PVC pipes are mounted into the shape of T-junctions. These junctions are then mounted on the MDF base, a hole is drilled on the PVC pipe at approximately 0.6 meters from the bottom, and another one inch PVC pipe is cut to a length of 0.5 meters, this pipe is inserted inside the three inch pipe, and the solar panel is mounted on it. Finally the motor and the gear are mounted on the side and linked using a chain for the horizontal axis and all the LDR's are mounted and wired.

4. SINGLE- AXIS TRACKING SYSTEM

The single-axis solar tracking system analyzed in this paper consist of a PV panel rotating around a tilted shaft under the action of a Bidirectional Motor that is controlled according to the real sun position, estimated by means of two light intensity sensors[1]. The light sensors consist of two LDRs placed on either side of the panel separated by an opaque plate. Depending on the intensity of the sun rays one of the two LDR is shadowed and the other is illuminated. The LDR present on the side, in which the intensity of the sun rays is higher, will generate a stronger signal and the other will generate a weaker signal. The difference in the output voltage between the two LDRs will help in the movement of the PV panel in the direction in which the intensity of the sun rays is maximum[2]. In this PIC16F84 A microcontroller is used to command the DC motor by giving pulse signal to it. Relay controls the rotation of the motor either to rotate clockwise or anticlockwise [2].

4.1 DISADVANTAGE

This kind of tracker is most effective at equatorial latitudes where the sun is more or less overhead at noon. Due to the annual motion of the earth, the sun also moves in the north and south direction depending on the season and due to this the efficiency of single-axis is reduced since the single-axis tracker only tracks the movement of sun from east to west. During cloudy days the efficiency of single tracker is almost close to the fixed panel.

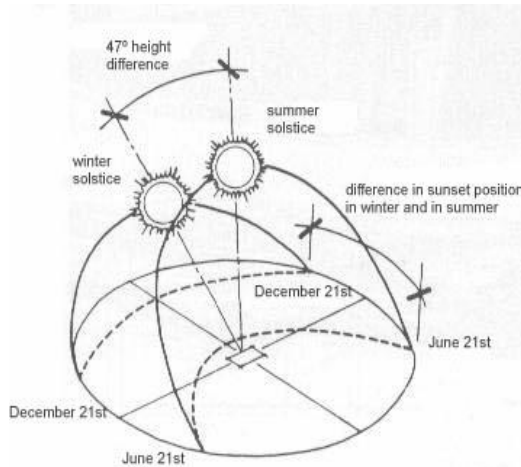

5. DUAL-AXIS SOLAR TRACKING SYSTEM

To overcome the disadvantages in the single-axis tracking system, a dual-axis tracking system is introduced. In dual-axis tracking system the sun rays are captured to the maximum by tracking the movement of the sun in four different directions. The dual-axis solar tracker follows the angular height position of the sun in the sky in addition to following the sun's east-west movement [3]. The dual-axis works in the same way as the single-axis but measures the horizontal as well as the vertical axis. The dual axis tracker in this paper [4] consists of two sets of photo resistor sensors, two AC motors and a PIC controller. One set of sensors and a motor is used to tilt the tracker in sun's east - west direction and the other set of sensors and the other motor which is fixed at the bottom of the tracker is used to tilt the tracker in the sun's north-south direction. When the sun moves in the northern direction the tracker has to track the path of the sun in anti-clockwise direction along the horizontal axis (east to west). If the sun moves in the southern direction then the tracker has to track the path of the sun in clockwise direction. The sensor senses the light from the sun and sends the signals generated by them to the PIC microcontroller. The controller detects the stronger signal and commands the motor to rotate in clockwise or anti-clockwise direction accordingly.

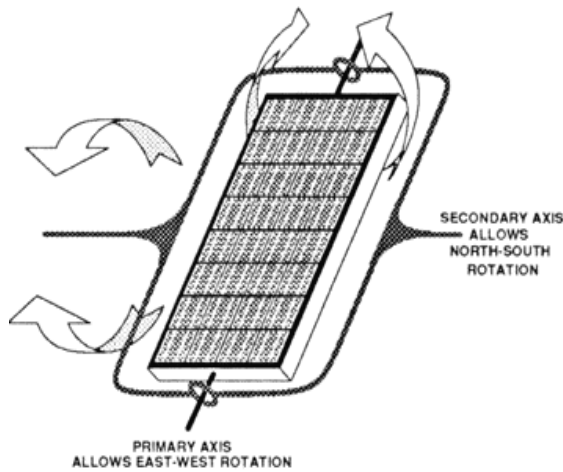

6. PROPOSED IDEA

In order to sustain in the market, these trackers must be designed to meet the user's requirement. Basically, there are four factors that must be taken into consideration in building a desired solar tracker. These factors are (1) Cost; (2) Reliability - Material and structure design; (3) Efficiency – Algorithm and circuit design and (4) Accuracy- Sensor positioning.

6.1 We can use DC motor instead of AC motor in the proposed solar tracker. The main advantage of DC motor over an AC motor is speed control, position control and operation at low speed. The AC motors are more expensive than DC motors for more horsepower rating. The speed of DC motor can be controlled with a less complicated control unit than the unit required for the AC motor. This can reduce the cost and the complexity of the circuit. Due to the precise speed control of the DC motor we can increase the efficiency of the tracker system when compared with the existing tracker system.

6.2 The efficiency of the dual-axis tracking system can be increased even more by placing a mirror or a concave lens on top of the panel. The use of lens or mirror increases the tracker's efficiency since large amount of sunlight gets concentrated on the panel and large power is generated. It can also reduce the size of the solar cell required to generate larger power. With this practice we can also achieve high optical efficiency.

6.3 Generally, cost will be the main component that is to be considered for the commencement of a project. In order to produce a low cost solar tracker, material being used must be appropriate for structure design that will lead to higher reliability and life span of the tracker. Besides these

the tracker must have good response of time and higher efficiency. Lastly, the sensor must be placed at the proper location on the tracker to increase the accuracy and the tracker will be facing to the light source perpendicularly at all times. To build an efficient solar tracking system at first it is essential to built an efficient algorithm which operates the whole system accurately.

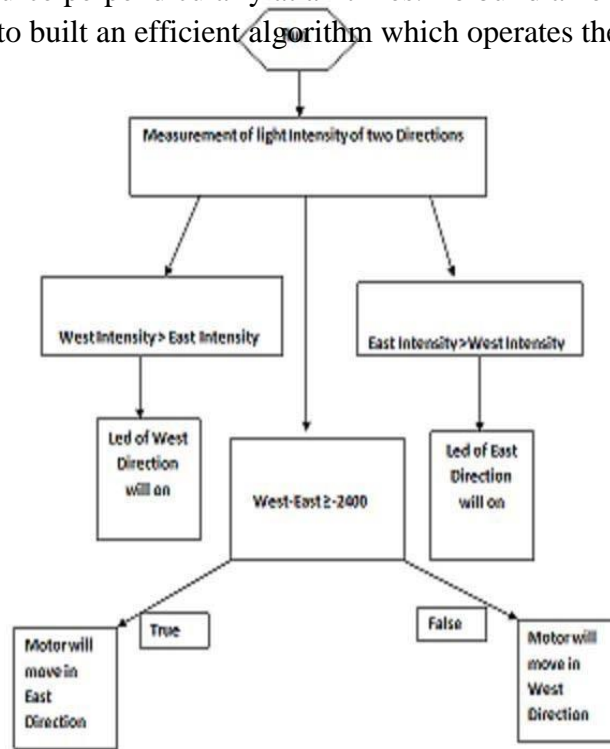

Solar Tracker Algorithm is to quickly determine to the best angle of exposure of light from the sun. A pair of sensors is used to point the East and West of the location of the light. Fig. 2 shows a flow chart of Solar Tracker Algorithm. At first two sensors are set which measure the temperature of two directions and then supply the data to the program which is running in particular logic. At first the output of the thermometer is multiplied by a numeric value 2400. Light intensity = $2400 \times V_0$ lux This is done because human eye is a very poor instrument for measuring light intensity, because the pupil can adjust constantly in response to the amount of light it receives[5].

After that two intensities are comparing with each other. If intensity of the light of one direction is greater than the other direction of light then the Led which represented the higher intensity of light will glow. The second part of the algorithm is, o intensity of one direction is subtracted from the other intensity and compares with a constant value -2400 which decide the movement of the machine in particular direction. The output of the program will control the movement of stepper motor. A PV panel is connected to the shaft of the stepper motor which is perpendicular to the direction of the sun. Stepper motor is mainly used in this work because Stepper motors have a wide range of applications. Some applications require that a stepper motor should rotate

continuously or periodically with a constant speed or a variable speed; some applications also require that it should position a device at the right time to a certain position according to a program and it consumes low power with respect to other machines [5],[6]-[7].

CONCLUSION

It has been proved through previous research that solar tracking system with single-axis freedom can increase energy output by approximately 20%, whereas the tracking system with double axis freedom can increase the output by more than 40%. Therefore this work in this paper is to develop and implement a solar tracking system with both degree of freedom and the detection of the sunlight using sensors. The control circuit for the solar tracker is based on a PIC16F84A microcontroller. This PIC is the brain of the entire tracking system, and it is programmed to detect the sunlight through sensors and then actuate the motor to position where maximum sunlight could be illuminated onto the surface of the solar panel. After many setbacks in testing of the solar tracker, a lot of time is needed to be set aside for verification and testing due to the unpredictability of the weather and debugging of errors. This tracking implementation is successfully achieved with complete design of two degree of freedom using the PIC microcontroller. Suitable components and gear dc motors are used for the prototype model, which exhibit a clear, stable and precise movement to face the sun.

REFERENCES

- [1] Tiberiu TUDORACHE, Constantin Daniel OANCEA and Liviu KREINDLER, "Performance Evaluation Of A Solar Tracking PV Panel", U.P.B. Sci. Bull., Series C, Vol.74, Iss. 1, 2012.
- [2] Asmarashid Ponniran, Ammar Hashim, and Handy Ali Munir, "A Design of Single Axis Sun Tracking System", The 5th International Power Engineering and Optimization Conference (PEOCO2011), June 2011.
- [3] Nader Barsoum, "Fabrication of Dual-Axis Solar Tracking Controller Project", Intelligent Control and Automation 2011, 2, 57-68.
- [4] M. Serhan and L. El-Chaar, "Two Axes Sun Tracking System: Comparison with a fixed system", International Conference on Renewable Energies and Power Quality (ICREPQ'10), March 2010
- [5] H. Wan Siew, "Solar Tracker", ENG499 capstone Project 2008.

[6] B. L. THERAJA, A. K.THERAJA “A Text Book of Electrical Technology”*AC and DC machines* Vol 2, 2005

[7] A. Altintas, “A Graphical Interface For Programming Stepper Motors Used at different kind of applications,” *Mathematical and computational applications*, Vol-14, No.2,pp.139-146,2009.

IJISE